

**TDS CONDUCTIVITY PROBE
DIRECT BOILER CONDUCTIVITY MEASUREMENT
(Two-pole cells with ATC Pt 100)
SPS-32**

DESCRIPTION

The ADCATROL SPS-32 conductivity probe is used to measure the conductivity (TDS) of the superheated water of boilers or condensate.

The probe is used in conjunction with the ADCATROL BCS controller and VPC valve series.

Two-pole cells for conductivity measurement of water in steam generators or boilers.

It is provided with Pt100 sensor for ATC temperature compensation in order to obtain an accurate reading of conductivity while operating with controllers provided with ATC input such as BCS-210 series.

The water contains impurities in form of dissolved solids and solid in suspension whose concentration increases when it is vaporized. Water treatment can reduce impurities to a certain level but it does not eliminate them completely and in certain conditions it might even increase them. As steam starts to be produced, the concentration of total solid in suspension (TDS) increases in the boiler's water. In case the TDS concentration is too high, dissolved salts concentration will be increased. This effect can contaminate the steam and cause damage to the system due to corrosion and salts incrustation of on thermal transference surfaces, (among other problems).

This high concentration is harmful and it is not acceptable in applications where steam is used for treatment of food, drinks and sterilization processes.

In order to limit the concentration of TDS to a suitable level a certain amount of the water of the boiler must be periodically eliminated (purge action) and replace by treated water.

SPS-32 probe together with BCS controller has been developed to purge all types of steam generators based on the measurement of TDS in the water of boiler. It activates the purge valve with a controlled cadence to avoid that an excess of purges generate energy losses and high consumption of treated water.



MAIN FEATURES

- Cell constant K=2
- Range 100 $\mu\text{S/cm}$ -1 to 10000 $\mu\text{S/cm}$ -1
- Two-pole electrodes in SS316L
- Body in SS316 and PFA (PEEK in option)
- Pressure 25 BAR (max. 32 bar)
- Temperature 200 °C (max. 240 °C)
- Temperature compensation (ATC) by Pt100 (optional Pt1000)
- Calibration by buffers in the controller
- Design for direct mounting in the boiler
- Process connection DIN 43650 (IEC 4440)
- Resistance to vibrations: max. 5 G RMS
- Protected against aggressive environments

OPTIONS: Connection Tee for boiler and blowdown valve connection

USE: Superheated boiler water and condensate

AVAILABLE MODELS: SPS-32

SIZES: DN 1/2"

CONNECTIONS: Screwed ISO 7/1 RP (BS21)
ANSI B1.20.1 (NPT)

INSTALLATION: Horizontal or vertical installation

ORDER REQUIREMENTS : SPS-32 probe for TDS with PT100 sensor for measurements up to 10000 $\mu\text{S}/\text{cm}^{-1}$ process connection 1/2" GAS, or 1/2" NPT

LIMITING CONDITIONS	
Maximum boiler pressure	32 bar
Maximum temperature	240 °C
Maximum ambient temperature	80 °C
Minimum distance from boiler tubes	20 mm
Maximum cable length (from probe to controller)	20 to 30 m
Minimum conductivity	100 μS
Protection rating	IP65

MATERIALS	
DESIGNATION	MATERIAL
Body	AISI 316L / 1.4404
EC electrodes	AISI 316L / 1.4404
Insulation	FPA (PEEK on request)

DIMENSIONS :

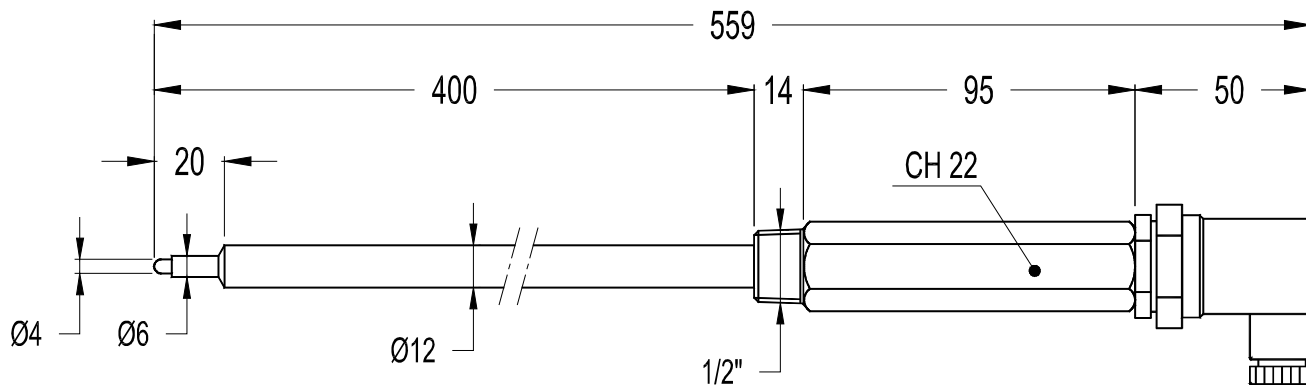

WEIGHT: 0,51 Kg

INSTALLATION: Directly to the boiler, in the way that the probe is always in contact with the water.
Any metallic parts near the probe must be at a minimum of 20mm from the central end pole.

INSTALLATION EXAMPLES:

Horizontal installation with a Tee piece type F-3220

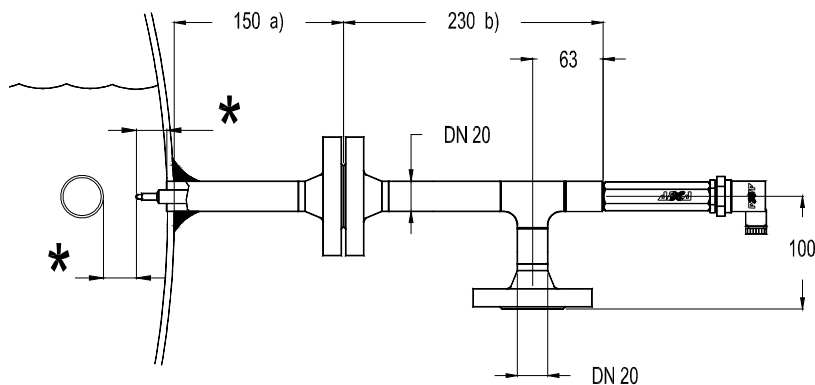

* 20 mm , minimum ; a) + b) ≤ 380 mm

Vertical installation on a boiler standpipe with a probe flange

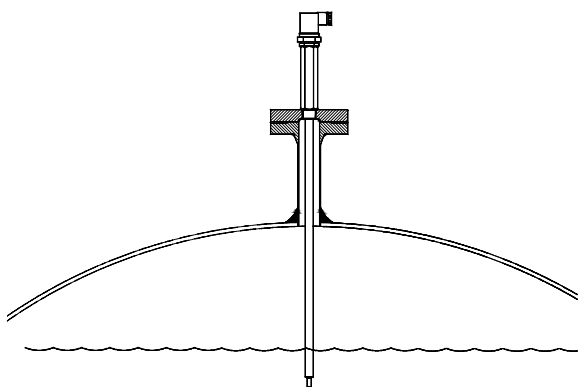

TYPICAL INSTALLATION

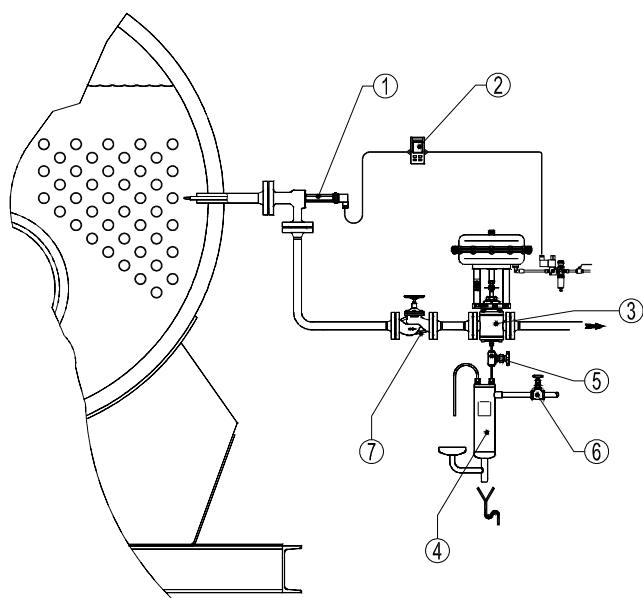

WIRING DIAGRAM

EXAMPLE OF CONNECTION CONTROLLER BCS-210

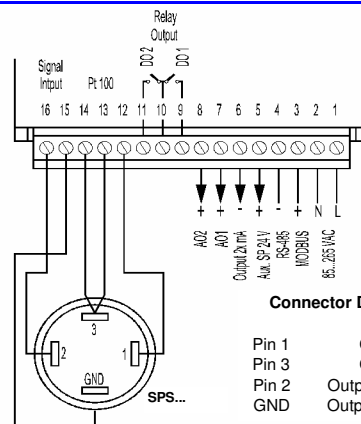

Connector DIN 43650

- Pin 1 Output Pt100
- Pin 3 Output Pt100
- Pin 2 Output Pole of EC
- GND Output Pole of EC

1	----	Power supply 85...265 V ac/dc
2	----	optional: 12 or 24 V ac/dc
3	+	RS-485 Modbus RTU communication
4	-	
5	+	Auxiliary power supply 24 Vdc 40 mA
6	-	Common to 24 Vdc and AO1 - AO2 outputs (option)
7	+	AO1 Analog output 4-20 mA of Conduct. (option)
8	+	AO2 Analog output 4-20 mA of Temp. (option)
9	○	DO1 Blow-down output of TDS. SPST Relay Common
10	⊗	
11	○	DO2 Hi and Lo Limit output of EC. SPST Relay
12	⊗	ATC by Pt100 input (Pt1000 in option)
13	⊗	
14	⊗	
15	Without Polarity	Performing input for sensors of:
16		2-poles Conductivity EC probes

Position	Designation
1	Adcatrol SPS-32 TDS probe
2	Adcatrol BSC-210 TDS controller
3	Adcatrol VPC-32 Blowdown valve
4	Adca SC32SS Sample cooler
5	Adca NV-400 Needle valve
6	GV32B Bronze globe valve
7	Adca VF Bellow sealed globe valve

OPERATION

The BCS controller (2) is programmed to continuously measure the electrical conductivity (1) of boiler water (closed related to the TDS) and compare it with the set point selected in the controller. It will open the blowdown valve (3) if the measured value is higher, or keep the valve closed until the measured value exceeds the set point.

It is recommended to install a heat recovery system (flash vessel, heat exchanger, etc) before connecting the wasted water to the BEX.